

CAD FILE:

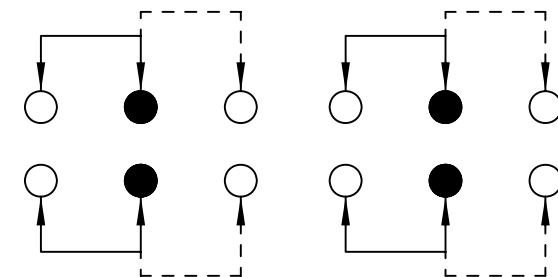

SCHEMATIC (NON-SHORTING)

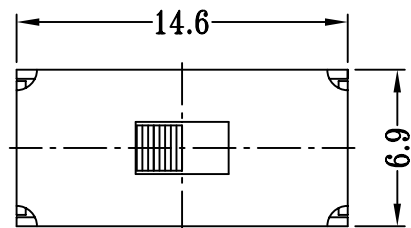
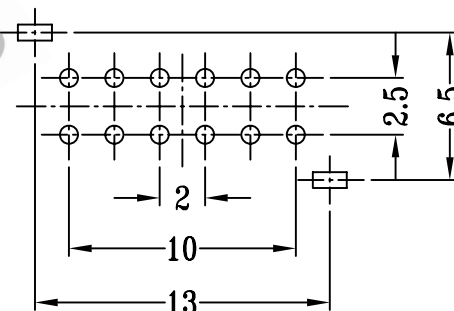
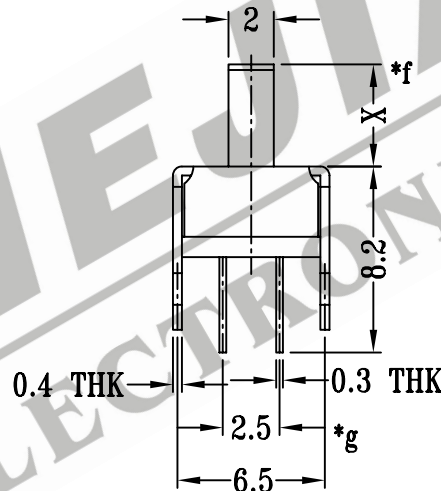
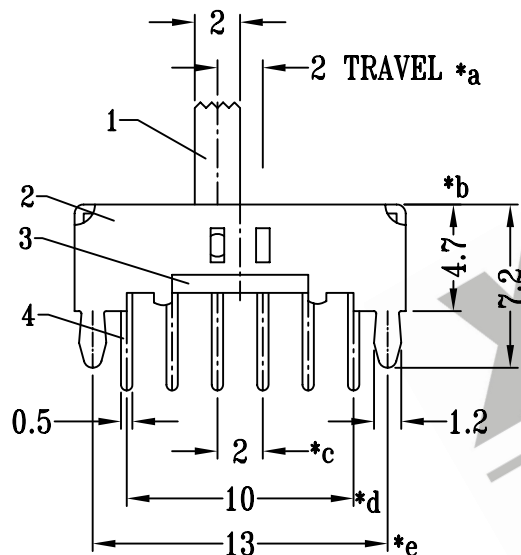

P.C.B LAYOUT

注:带"*"表示关键尺寸(7个)

8					TOLERANCE UNLESS SPECIFIED	SHENZHEN XIEJIA ELECTRONICS CO.,LTD.				
7										
6	CONTACT CLIP	PBS	4	Ag CLAD	WITHIN: 1.5±0.1mm OVER : 1.5±0.2mm	ISSUE	DATE	DESCRIPTIONS OF REVISION		APPD.
5	SPRING PLATE	STAINLESS STEEL	2	NATURAL						
4	TERMINAL	BRASS STRIP	12	Ag PLATED OVER Ni PLATED	TITLE: VERTICAL SLIDE SWITCH		UNIT : mm	DRWG NO.: XJ-DR-SS42D02-00		
3	BASE	PHENOLIC RESIN	1	NATURAL	MODEL: SS-42D02		SCALE : 3:1	DWN.	ZHOUYU	2002-5-17
2	FRAME	STEEL STRIP	1	Ni PLATED				CHK'D	FANGYING	2002-5-17
1	KNOB	POM	1	BLACK	ALL MATERIALS MUST BE COMPLIANT TO ROHS		APPD.	KANGXINAN	2002-5-17	
NO.	PARTS	MATERIALS	Q'TY	FINISH						